

Germline E-cadherin mutations in hereditary diffuse gastric cancer: assessment of 42 new families and review of genetic screening criteria

A R Brooks-Wilson, P Kaurah, G Suriano, S Leach, J Senz, N Grehan, Y S N Butterfield, J Jeyes, J Schinas, J Bacani, M Kelsey, P Ferreira, B MacGillivray, P MacLeod, M Micek, J Ford, W Foulkes, K Australie, C Greenberg, M LaPointe, C Gilpin, S Nikkel, D Gilchrist, R Hughes, C E Jackson, K G Monaghan, M J Oliveira, R Seruca, S Gallinger, C Caldas*, D Huntsman*

See end of article for authors' affiliations

J Med Genet 2004;41:508–517. doi: 10.1136/jmg.2004.018275

Correspondence to:
D Huntsman, B.C. Cancer Agency, 600 West 10th Avenue, Vancouver, BC, Canada V5Z 4E6; dhuntsma@bccancer.bc.ca

Correspondence to:
C Caldas, Department of Oncology, University of Cambridge, Hutchison/MRC Research Centre, Level 3, Addenbrooke's Hospital, Cambridge CB2 2XZ, UK; cc234@cam.ac.uk

Revised version received 9 January 2004
Accepted for publication 19 February 2004

Background: Mutations in the E-cadherin (CDH1) gene are a well documented cause of hereditary diffuse gastric cancer (HDGC). Development of evidence based guidelines for CDH1 screening for HDGC have been complicated by its rarity, variable penetrance, and lack of founder mutations.

Methods: Forty three new gastric cancer (GC) families were ascertained from multiple sources. In 42 of these families at least one gastric cancer was pathologically confirmed to be a diffuse gastric cancer (DGC); the other family had intestinal type gastric cancers. Screening of the entire coding region of the CDH1 gene and all intron/exon boundaries was performed by bi-directional sequencing.

Results: Novel mutations were found in 13 of the 42 DGC families (31% overall). Twelve of these mutations occur among the 25 families with multiple cases of gastric cancer and with pathologic confirmation of diffuse gastric cancer phenotype in at least one individual under the age of 50 years. The mutations found include small insertions and deletions, splice site mutations, and three non-conservative amino acid substitutions (A298T, W409R, and R732Q). All three missense mutations conferred loss of E-cadherin function in *in vitro* assays. Multiple cases of breast cancers including pathologically confirmed lobular breast cancers were observed both in mutation positive and negative families.

Conclusion: Germline truncating CDH1 mutations are found in 48% of families with multiple cases of gastric cancer and at least one documented case of DGC in an individual under 50 years of age. We recommend that these criteria be used for selecting families for CDH1 mutational analysis.

Gastric cancer is one of the leading causes of cancer death worldwide.¹ There are two major histological variants: (1) diffuse gastric cancer (DGC) and (2) intestinal type gastric cancer (IGC).² In the diffuse form, a malignant infiltrate containing cells that have a large globule of intracellular mucin and an eccentric nucleus permeates the wall of the stomach, often spreading under histologically normal mucosa. In the more common intestinal type, the malignant cells exist in glandular structures with variable levels of differentiation. Approximately 10% of gastric cancers have a mixed phenotype; the genetic basis for the phenotypic heterogeneity in these cases is believed to be somatic E-cadherin loss in the diffuse gastric cancer component of such tumours.³ The relative frequency of diffuse and intestinal cancers varies with the population surveyed and the classification criteria used.⁴

A small proportion of diffuse gastric cancers, perhaps as few as 1%, occur in families with autosomal dominant gastric cancer susceptibility.⁵ Although only a minority of gastric cancers are hereditary, the identification of such cases offers the opportunity to provide genetic counselling, genetic testing for gastric cancer susceptibility, and gastric cancer risk reduction strategies to as yet unaffected family members at risk for the development of gastric cancer. Gastric cancer is usually lethal if diagnosed at a late stage (<20% 5 year survival) but is curable if resected before invasion through the gastric wall (>90% 5 year survival¹). Unfortunately, most gastric cancers, and DGCs in particular, become symptomatic

only when they are incurable. Effective treatment of familial gastric cancer, therefore, depends on the presymptomatic identification of individuals at risk for this cancer.

The majority of families with autosomal dominant gastric cancer susceptibility have diffuse type gastric cancer. Hereditary diffuse gastric cancer (HDGC) has also been noted to occur in families in combination with breast cancer, particularly lobular breast cancer (LBC).⁶ In 1999 the International Gastric Cancer Linkage Consortium (IGCLC) defined hereditary diffuse gastric cancer by clinical criteria that include: (1) any family with two or more documented cases of diffuse gastric cancer in first or second degree relatives with one case under the age of 50, or (2) three documented diffuse gastric cancers in first or second degree relatives at any age.⁷

Germline mutations in the E-cadherin gene (epithelial cadherin, CDH1, OMIM# 192090) have been demonstrated to underlie disease in some but not all HDGC families, but not in hereditary intestinal type gastric cancer families.⁷ CDH1 mutations were first described in three Maori families with autosomal dominant diffuse gastric cancer.⁸ Since then, germline loss of function mutations have been demonstrated

Abbreviations: FAP, familial adenomatous polyposis; FFPE, formalin-fixed paraffin embedded; HDGC, hereditary diffuse gastric cancer; HNPCC, hereditary non-polyposis colon cancer; IGC, intestinal type gastric cancer; LCIS, lobular breast carcinoma in situ; PJS, Peutz-Jeghers syndrome

to underlie approximately 30% of HDGC in families of various ethnic backgrounds.^{9,10} E-cadherin is a member of the cadherin family of adhesion molecules, which are transmembrane glycoproteins mediating calcium-dependent cell–cell adhesion.¹¹ E-cadherin is critical for establishing and maintaining polarised and differentiated epithelia during development. It also plays important roles in signal transduction, differentiation, gene expression, cell motility, and inflammation. Somatic loss of E-cadherin expression is considered to be a defining feature of both DGC and lobular breast cancer.^{12,13}

We ascertained 43 apparent cases of hereditary gastric cancer and screened them for germline E-cadherin mutations to determine the optimum criteria for clinical testing and to identify other cancer risks associated with germline E-cadherin mutations.

METHODS

Families and patients

A total of 43 families were identified: 18 from Canada, five from the United States and 20 from the United Kingdom. Ethnicity was known in 20/43 families. Of these, 15 were of Northern European descent. The others were of Spanish, Haida, French-Canadian, and Italian descent. The criteria used for ascertainment and testing are described in table 1. Criteria 1 and 2 are the IGCLC criteria for HDGC families. Criteria 1A and 2A are similar to 1 and 2 but have been relaxed to account for the difficulty in obtaining pathologic confirmation on referral cases. The age of onset of GC in these families ranged from 9 to 65 years of age. Other cancers seen in these families include lobular breast, colon, prostate, ovarian, head and neck, and oesophageal cancers. Examples of two of the HDGC families are shown in figs 1 and 3A. Constitutional genomic DNA was extracted by standard methods from a blood sample from one affected individual of each family, usually the proband. In two families, blood samples from an as yet unaffected family member were used (table 2); in one family, an obligate carrier was screened because DNA of an affected family member was unavailable and, in another family, an at risk first degree relative was screened. In both cases, a mutation was found. The investigations were performed after approval by the Clinical Research Ethics Board of the University of British Columbia. Informed consent was obtained from each subject, or next of kin in the case of a deceased affected individual.

DNA extraction

Patients' peripheral blood samples were collected in EDTA tubes. The buffy coat layers of whole blood were treated with Puregene RBC lysis solution (Gentra Systems, MN, USA) and cell wash. A portion of white cells was used for DNA extraction and remaining cells were stored in freezer media. Puregene DNA Purification Kit (Gentra Systems) was used and the manufacturer's manual was followed for genomic DNA isolation.

Paraffin embedded sections from normal tissue were deparaffinised with xylene for 5 min at room temperature and centrifuged at 14 000 rpm for 3 min. After removal of the xylene, the samples were treated with 100%, 70% and 50% ethanol series for rehydration. Pellets were dried and incubated with Proteinase K (10 mg/ml Proteinase K, 1 M KCl, 1 M Tris pH 8.0, 1 M MgCl₂) at 56°C overnight and then boiled to inactivate the enzyme and centrifuged at 14 000 rpm. The supernatant was purified by phenol/chloroform extraction. DNA was precipitated with 100% ethanol, dried at room temperature and resuspended with ddH₂O.

Variant detection sequencing

Primers were designed using Primer 3 (http://www-genome.wi.mit.edu/cgi-bin/primer/primer3_www.cgi). Forward and reverse primers incorporated the -21M13F (TGTA AACGACGGCCAGT) or M13R (CAGGAAACAGCTATGAC) extensions, respectively, at their 5' ends. The sequences of all primers used in this study, and their annealing temperatures, are shown in table 3. PCR reactions were carried out in a volume of 20 µl containing 10 ng genomic DNA template, 1 mM MgSO₄, 0.5 µM of each PCR primer, 2 mM dNTPs, 1×Pfx Amplification Buffer and 0.25 U Platinum Pfx DNA polymerase (Invitrogen, ON, Canada). Thirty cycles of 30 s at 94°C, 30 s at a primer pair specific annealing temperature of 50–65°C and 1 min at 68°C were performed in programmable thermocyclers (MJ Research PTC-225 or Tetrads, Waltham, MA). A 3 µl aliquot of each PCR reaction was run on a 2% agarose gel to confirm the size, quantity, and purity of each PCR product. The remaining 17 µl of PCR product was purified using AmPure magnetic beads (Agencourt Bioscience, Beverly, MA) and eluted in a volume of 30 µl of TE (Tris-EDTA pH 8.0) according to the manufacturer's instructions. A 2 µl aliquot of purified PCR product was then cycle sequenced using Big Dye Terminator Mix V.3 at 0.25× chemistry in a total volume of 4 µl (Applied Biosystems, Foster City, CA). Both forward (-21M13F primer) and

Table 1 CDH1 mutation status and study criteria

Criteria no	Definition	Families (n)	Truncating mutations (n)	Splice site mutations (n)	Missense mutations (n)	Total number of mutations
1	Two or more documented cases of DGC in first degree relatives, with at least one diagnosed before age 50	15	5	1	2	8 (53%)
1A	Two or more cases of GC, with at least one DGC diagnosed before age 50	10	3	1	0	4 (40%)
2	Three or more documented cases of DGC in first degree relatives, diagnosed at any age	1	0	0	0	0
2A	Three or more cases of GC, diagnosed at any age, with at least one documented case of DGC	3	0	0	0	0
3	Isolated individual diagnosed with DGC at less than 45 years of age	9	0	0	0	0
4	Isolated individual diagnosed with both DGC and lobular breast cancer (no other criteria met)	0	0	0	0	0
5	One family member diagnosed with DGC and another with lobular breast cancer (no other criteria met)	3	0	0	0	0
6	One family member diagnosed with DGC and another with colon cancer (no other criteria met)	1*	0	0	1	1 (100%)
7	Intestinal gastric cancer	1	0	0	0	0

*Family member with signet ring carcinoma of the colon.

reverse (M13R primer) directions were sequenced. Cycle sequencing reactions consisted of 30 cycles of 10 s at 96°C, 5 s at 52°C (-21M13F forward primer) or 43°C (M13R reverse primer), and 3 min at 60°C. Reaction products were precipitated with isopropyl alcohol, washed with 70% ethanol, and resuspended in 8 µl of double distilled water before loading on ABI 3700 capillary sequencers. Sequence reads were base-called using Phred and sequence reads assembled with reference sequences using Phrap.^{14, 15} Contigs of sequence traces corresponding to each exon were examined using PolyPhred¹⁶ for detection of heterozygotes and visualised in Consed¹⁷ to facilitate verification of sequence variants by examination of individual traces.

Single strand conformation polymorphism (SSCP) analysis of CDH1 for formalin-fixed paraffin embedded (FFPE) DNA samples

In four families (F10, F19, F20, and F21), only DNA extracted from paraffin tissue blocks was available. In these cases, the CDH1 gene was screened by SSCP.

FFPE germline DNA from six samples were screened for CDH1 mutations by PCR of all exons and intron-exon boundaries followed by SSCP analysis on 8% polyacrylamide, 10% glycerol, and 0.5×TBE gels. Primer sequences were based on those reported previously,¹³ except for exons 1–5, which were amplified using new primers (EX1F: 5'-TACGGGGGGCGGTGCCT-3'; EX1R: 5'-CTGGGGCGCGGAGCTTG-3'; EX2F: 5'-TACCCCGGTTCATCTACC TTT-3'; EX2R: 5'-GCAATTTCCTGGCCCTTCC-3'; EX3AF: 5'-GTCTTAATCTGTCCAATTCC-3'; EX3AR: 5'-GCGTAGA CCAAGAAATGGAT-3'; EX3BF: 5'-TACAGTCAAAGGCC TCTACG-3'; EX3BR: 5'-AAACAACAGCGAATTCTCAG-3'; EX4R: 5'-CCAGAGAAACAGAGAAC-3'; EX5F: 5'-CTAATT CTTTCTTTCATTITG-3'; EX5R: 5'-TGGGTGGATGTTACCC CG-3'). PCR was performed in a 20 µl reaction volume with a buffer of 20 mM Tris-HCl pH 8.4, 50 mM KCl, 1 mM dNTPs, 1–3.5 mM MgCl₂ (1.0 mM for exon 1; 1.5 mM for exons 2, 3A, 3B, 7, 8, 12, 14; 3.0 mM for exons 5, 6, 9, 11, 15; 3.5 mM for exons 10, 16), 0.45 µM each primer, 0.05 U Taq polymerase (Platinum Taq, Invitrogen Life Technologies, USA) and 2.0 µCi α-³³P. Furthermore, 5% DMSO was added to exon 1 PCR. The following cycling conditions were used:

30 s at 94°C, 30 s at optimised annealing temperatures ranging from 51°C to 68°C (51°C for exon 8, 56°C exon 9, 57°C exon 5, 58°C exon 4, 60°C exon 3A, 62°C exons 3B, 6, 7, 10, 64°C exons 11, 12, 14, 16, 65°C exon 15, 66°C exon 13, and 68°C exons 1, 2) and 45 s at 72°C. Reaction products were diluted 1:1 with denaturing buffer (formamide with 0.025% xylene cyanol and 0.025% bromophenol blue) and heated to 94°C for 4 min before loading. Two sets of gel run conditions, 18 h at 4°C and 22 h at room temperature, were used except for exon 1 where only the room temperature run was done. Products were detected by autoradiography. For exons containing any possible band shifts the PCR was repeated. Samples were run on a 2% agarose gel and purified using a MinElute gel extraction kit (Qiagen, Valencia, CA) and eluted into a volume of 10 µl according to the manufacturer's instructions. A 2 µl sample of purified product was then sequenced using a Big Dye Terminator V.3 cycle sequencing kit (Applied Biosystems, Foster City, CA) in a final volume of 10 µl. All samples were sequenced in both directions. Cycle sequencing conditions were: initial denaturation of 96°C for 3 min followed by 25 cycles of 96°C for 30 s, 58°C for 30 s, and 60°C for 2 min. Reaction products were precipitated with ethanol/sodium acetate, washed with 70% ethanol, and resuspended in 15 µl of template suppression reagent (Applied Biosystems, Foster City, CA) before loading on an ABI capillary sequencer.

RT-PCR assay for IVS11+5 splice site mutation

RNA was extracted from a skin biopsy using Trizol (Invitrogen, ON, Canada). The RNA was DNaseI treated prior to being reverse transcribed. DNaseI treatment was carried out in a final volume of 10 µl containing 1 µg RNA 1× DNaseI buffer and 1 U DNaseI. Samples were incubated at room temperature for 15 min, 0.5 µl of 25 mM EDTA was added, and the samples were heat inactivated at 65°C for 10 min. The reverse transcription was performed in a volume of 25 µl containing 1×MMLV buffer, 8 mM DTT, 400 µM dNTP, random hexamers, and 400 U MMLV. The samples were incubated at room temperature for 10 min and 37°C for 1 h followed by heat inactivation of the reverse transcriptase at 65°C for 10 min. A 1 µl aliquot of reverse transcribed product was amplified in a final volume of 25 µl containing

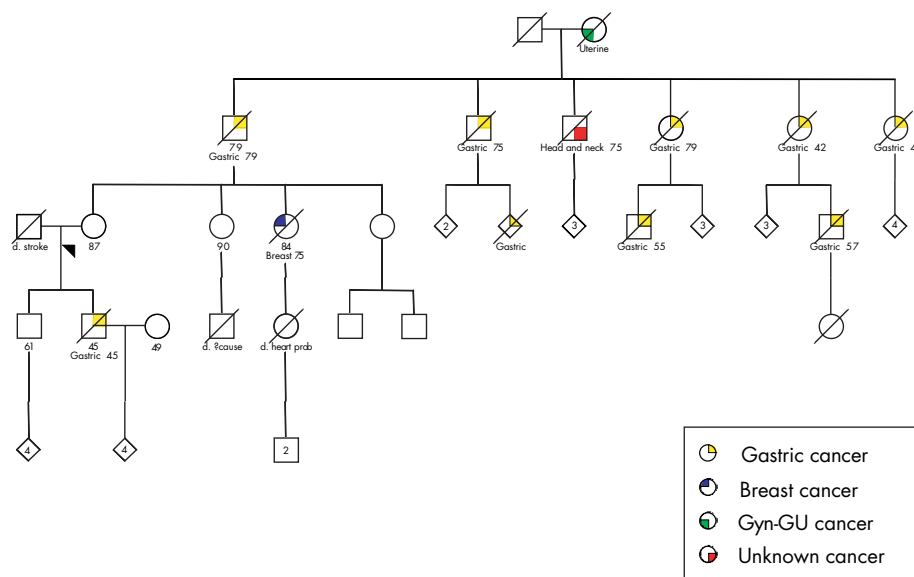

Figure 1 Family F4, showing autosomal dominant inheritance of gastric cancer with variable age of onset; the family has a mutation in the CDH1 gene (see table 2 and fig 2).

1×PCR buffer, 1.5 mM MgCl₂, 200 μM dNTP, 0.5 μM forward and reverse primer and 1 U Taq polymerase (Invitrogen, ON, Canada). Cycling conditions were as follows: initial denaturation at 94°C for 1 min, followed by 35 cycles of 94°C for 30 s, 60°C for 30 s, and 72°C for 1 min. Samples were run on a 2% agarose gel for visualisation. For the patient sample both bands were excised from the gel and purified using a QIAquick gel extraction kit and eluted into a 30 μl volume. A 1.5 μl aliquot of purified product was then sequenced using a Big Dye Terminator V.3 cycle sequencing kit (Applied Biosystems, Foster City, CA) in a final volume of 10 μl. Cycle sequencing conditions were: initial denaturation of 96°C for 3 min followed by 25 cycles of 96°C for 30 s, 55°C for 30 s, and 60°C for 2 min. Reaction products were precipitated with ethanol/sodium acetate, washed with 70% ethanol, and resuspended in 15 μl of template suppression reagent (Applied Biosystems, ON, Canada) before loading on an ABI capillary sequencer.

Functional assessment of missense variants Construction of the plasmids encoding wild type and mutant E-cadherins

CHO-K1 (Chinese hamster ovary) cells stably expressing the E-cadherin cDNA mutants were established by electroporation as previously described.^{18,19} Briefly, mutant plasmids were obtained by nested PCR using specific primers using wild type E-cadherin cloned in pcDNA3 as DNA template (G2195A: For 5'-CTGTTTCTCAGAGGAGAGCG-3', Rev 5'-CGCTCTCTGAAGAAACAG-3'; T1225C: For 5'-AATACCC CAGCGCGGAGG-3', Rev 5'-CCTCCGCGCTGGGTATT-3'; G892A: For 5'-ACAATACCGCCATCGCTTAC-3', Rev 5'-GATGGCGGTATTGTAGGTGT-3'). After transfection, cells were grown at 37°C under 5% CO₂ in humidified air, in a-MEM (+) medium (Gibco BRL) supplemented with 5% foetal bovine serum, 2 mM L-glutamine, 1% penicillin/streptomycin, and 1 mg/ml geneticin. Single cell clones were selected and analysed for E-cadherin expression by Western blotting, using the human E-cadherin monoclonal antibody HECD1 (R&D System, 1/3500 dilution) for protein staining.

At least two independent clones for each cell line were used in each experiment, to exclude clonal dependence of the results.

Cell aggregation assay

As previously reported,^{18,19} the ability of cells to aggregate was characterised in a fast aggregation assay. Briefly, single cell suspensions of transfected cells were incubated in an isotonic buffer containing 1.25 mM Ca²⁺. Particle diameters were measured at the start (T₀) and after 30 min (T₃₀), using an LS200 particle size counter (Coulter Electronics). Results were plotted against the percentage of volume distribution. The E-cadherin-blocking antibody MB2 (1/20 dilution) was used as a control for inhibition of aggregation.

Collagen invasion assay

The invasion assay was performed as previously described.^{18,19} Briefly, collagen gels with a minimum thickness of 250 μm, were prepared in a 6 well plate (Nunc International, Rochester, NY), from a collagen type I solution (Upstate Biotechnology, Lake Placid, NY), and polymerised overnight at 37°C. Mutant E-cadherin expressing cells (1×10⁵) were incubated on top of the collagen gels, for 24 h at 37°C and invasion indices (%) expressed as ratios between the number of invasive cells inside the gel and the total number of cells, counted in at least 12 microscopic fields.

RESULTS

Variant detection sequencing of the CDH1 gene

Ten loss-of-function mutations including two insertions, five deletions, two splice site substitutions, and one complex deletion/insertion involving a splice site were seen in 10 different families (table 2). Three missense mutations were also identified (table 2). Their functional consequences are described below. All mutation carriers found were heterozygous for a specific mutation, consistent with the autosomal dominant inheritance of HDGC in these families. No two families had the same mutation. All mutations seen were novel (not seen before). Of the three mutations involving

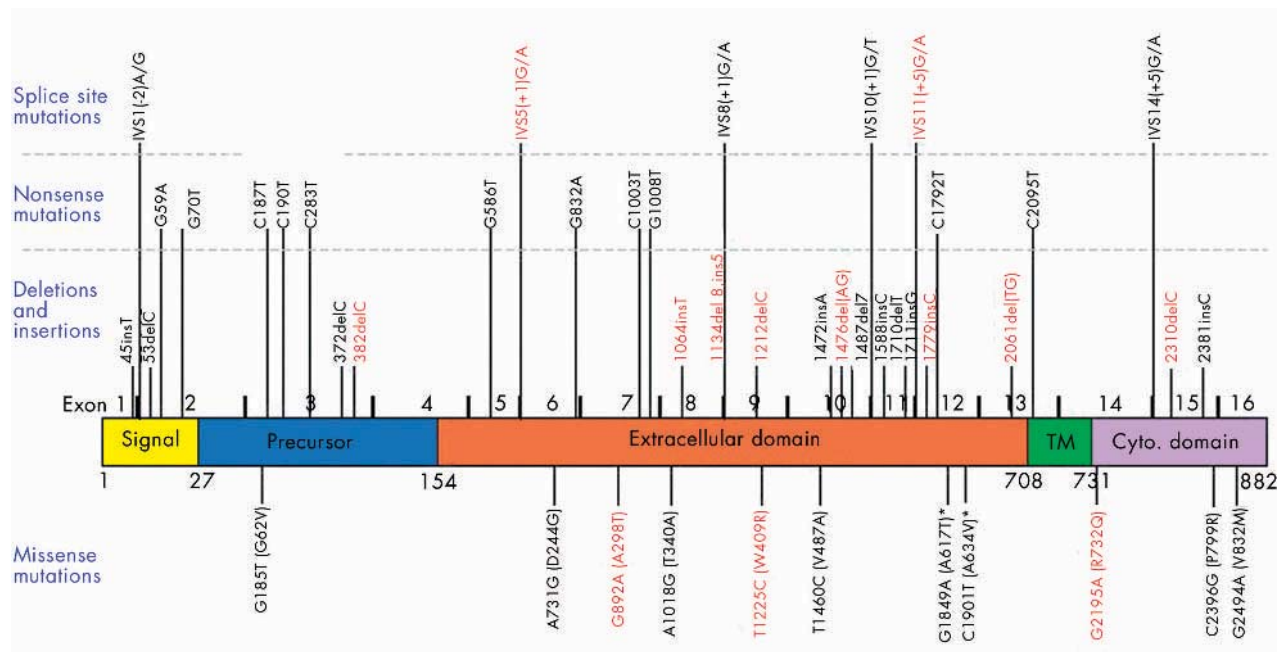

Figure 2 CDH1 mutations found to date. Truncating and splice site mutations are found above the schema, missense mutations below it. Mutations found in the present study are indicated in red. Those marked with an asterisk have also been reported as somatic mutations in sporadic DGC. Polymorphisms are not shown.

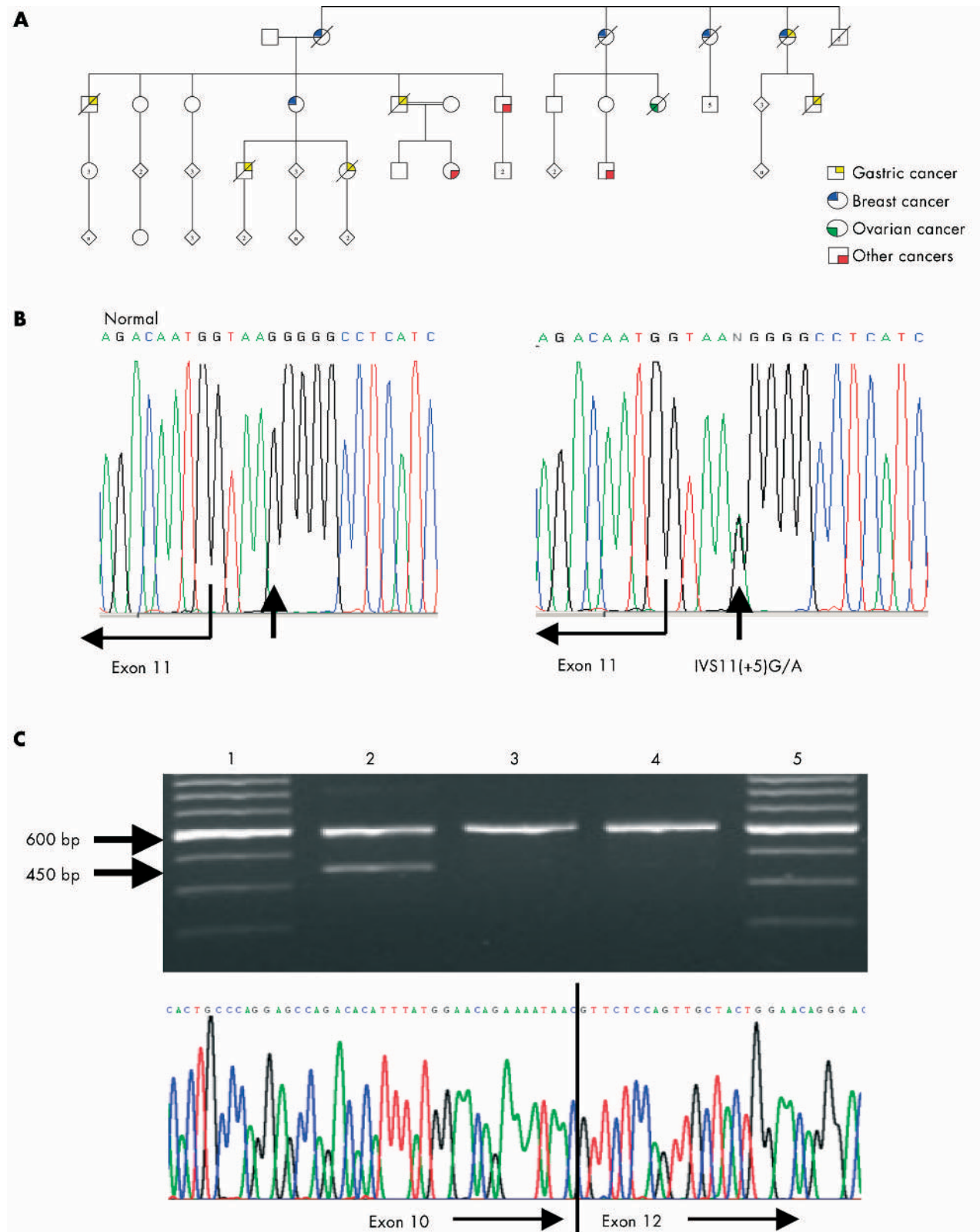

Figure 3 (A) Family F11. (B) Sequencing of genomic DNA. Arrow indicates location of G to A substitution. (C) Results of RT-PCR. Lane 2 shows both the normal band (upper band) and the band with deletion of exon 11. Lanes 3 and 4 show the RT-PCR from normal control samples. Sequencing chromatogram confirms complete loss of exon 11.

splice sites, the one in family F1 was a G to A substitution of the highly conserved (+1) position of the splice donor site of IVS5, a substitution almost certain to have functional consequences for the splicing of that intron, and likely to lead to in-frame deletion of exon 5 from the transcript. Consistent with this predicted effect being deleterious for the function of E-cadherin, an exon 5 deletion has previously been described as a somatic CDH1 mutation in invasive lobular breast cancer.²⁰ The second splice site mutation was a G to A substitution at the (+5) position of IVS11 in family F11 (fig 2). This mutation leads to the deletion of exon 11 from the CDH1 transcript as demonstrated by RT-PCR (fig 3). The third splice site variant involved a deletion of the exon 8/ intron 8 splice boundary and would be expected to have an adverse functional effect. All the mutation positive families were of Northern European descent except for family F10 (Italian) and family F42 (Spanish). All the mutations in this study have been deposited into the database, dbSNP (<http://www.ncbi.nlm.nih.gov/SNP/>).

A total of 29 DGC families were identified that did not have CDH1 mutations within their protein-coding exons. Germline deletion of the entire CDH1 gene can be excluded for 23/29 of these families by the presence of heterozygosity for polymorphisms within CDH1 exons or in flanking intronic sequences. Deletion of single whole exons of CDH1 cannot be ruled out by this screening method; however, this mechanism is unlikely to account for all of the 29 families studied that did not show CDH1 mutations.

Functional assays of missense mutations

Sorting Intolerant from Tolerant (SIFT)²¹ uses evolutionary conservation to predict the impact of amino acid substitutions on protein function. SIFT analysis predicted that all three missense mutations identified in DGC families affect conserved residues and would be expected to have deleterious effects on protein function. Residue W409 and R732 are conserved in human, mouse, rat, *Xenopus*, and zebrafish, implying an important function. W409 is found in the third

Table 2 Details of the gastric cancer families in the study and mutations detected

Family no	Cancer type, age	Study criteria met	Other family members with gastric cancers, n (ages)	Family members with breast cancer, n (confirmed lobular breast cancer)	CDH1 mutation: exon, nucleotide (amino acid)	Type of mutation
F1	DGC, 40	1A	3 (36, 48, 50)	1	IVS5(+1) G>A	Splice site
F2	DGC, 33	1	2† (35, 42)	0	Exon 12, 1779insC	Insertion
F3	DGC, 9	1A	1 (40)	0	Negative	
F4	Unaffected	1A	8 (42, 45, 49, 57, 75, 79, 79, unknown)	1	Exon 15, 2310delC	Deletion
F5	Colon, 74	1	4 (25†, 42†, 50, unknown)	3	Negative	
F6	DGC, 45	5	0	3 (1)	Negative	
F7	DGC, 51	6*	0	0	Exon 9, T1226C (W409R)	Missense
F8	DGC, 62	2A	3 (58, ~60, 63)	0	Negative	
F9	DGC, 61	1	4 (17, 32†, 46†, 47†)	4	Exon 9, 1212delC	Deletion
F10	DGC, 32	1A	6 (40, 42, 45, 50, 55, 56)	2	Exon 3, 382delC	Deletion
F11	DGC 48	1	2 (44†, 44†)	5 (1)	IVS11(+5) G>A	Splice site
F12	DGC, 31	3	0	0	Negative	
F13	Unaffected (colonic polyp)	1	2 (36†, 70†)	4 (2)	Exon 14, G2195A (R732Q)	Missense
F14	DGC, 65	2A	2 (44, 70)	0	Negative	
F15	Bilateral lobular breast cancer, 52	5	1 (40†)	1	Negative	
F16	DGC, 24	1	1† (47)	0	Exon 13, 2061del (TG)	Deletion
F17	Prostate, 72	1A	5 (30, 37†, 39†, 50, 70)	0	Negative	
F18	DGC, 32	1A	1 (40)	0	Exon 10, 1476del (AG)	Deletion
F19	DGC, 74	3	0	3 (2)	Negative by SSCP	
F20	DGC, 75	2A	2 (55; 72)	0	Negative by SSCP	
F21	DGC, 58	2A	1 (59)	0	Negative	
F22	GC, 61	7	6 (54†; 59; 74; 3 in 70s)	2	Negative	
F23	Unaffected	1A	2 (42†; 60s)	2	Negative	
F24	Oesophageal, 62	1A	3 (~50, 63, 65)	0	Negative	
F25	DGC, 34	1	2 (50, 58†)	0	Exon 8, 1064insT	Insertion
F26	DGC, 36	1	2 (32†, 33)	0	Exon 7, G892A (A298T)	Missense
F27	DGC, <50	3	0	0	Negative	
F28	DGC, 43	1A	1 (60)	0	Negative	
F29	DGC, <50	3	0	0	Negative	
F30	DGC, 55	1	3 (44†, 52†, unknown)	2	Negative	
F31	DGC, <50	3	0	0	Negative	
F32	DGC, 45	3	0	0	Negative	
F33	DGC, 48	3	0	0	Negative	
F34	DGC, 33	1	2 (35†, unknown)	0	Negative	
F35	Oesophageal, 60	1	3 (34†, 44†, 68)	0	Negative	
F36	GC†, 46	1A	1 (unknown)	0	Negative	
F37	DGC, 36	3	0	0	Negative	
F38	DGC, 39	1	3† (33, 67, 69)	0	Negative	
F39	DGC, 48	3	0	0	Negative	
F40	DGC, 38	1	1 (54)	0	Negative	
F41	DGC, 27	1	3 (30†; 32†; unknown)	0	Exon 8, 1134 del8, ins5	Deletion and insertion
F42	DGC, 41	1	2 (44†, 57)	0	Negative	
F43	DGC, <50	3	0	0	Negative	

†DGC, confirmed by pathology report; ‡IGC, confirmed by pathology report; *Mixed histology, confirmed by pathology report.

Table 3 Primer sequences used in the study and their annealing temperatures

Exon	Forward 5'-3'	Reverse 5'-3'	T _m (°C)
1	M13F GTGAACCCCTCAGCCAATCAG	M13R TGACGACGGGAGAGGAAG	63
2	M13F TGTTGGTTTCGGTGAGCAG	M13R GGTGTGGGAGTGCAATTCT	61
3	M13F CGCTCTTGGAGAAGGAATG	M13R AACGGTACCAAGGCTGAGAA	58
4	M13F GCTGTCTGGCTAGGTGGAC	M13R TTTTCCCTTCTCTCCTTGG	58
5	M13F GAAAGGGAAAAGACCCAGTG	M13R GGATCCAGCATGGGTGAC	58
6	M13F GCCCCTTCTCCATGTTT	M13R CTTTGGGCTTGACAACACT	56
7	M13F GGGCAGAATTGGATTAAGCA	M13R TGTCCACGGGATTGAGCTA	57
8	M13F CTGGGCTAGGCCAAAGGT	M13R CCATGAGCAGTGGTGACACT	57
9	M13F AATCCTTTAGCCCCCTGAGA	M13R AGGGGACAAGGGTATGAACA	61
10	M13F CCAAAGCAACAGTTAAGGA	M13R CAAATGACAAAATGCCATGA	56
11	M13F AGCGCTTAAGCCGTTTTCA	M13R GAGGGGCAAGGAACTGAAC	60
12	M13F AAGGCAATGGGGATTTCATA	M13R ATTGAAAGTGGGGATCTGG	59
13	M13F CAATTTATTCTGGAATGAGCTTT	M13R CAGGAAATAAACCTCTCCATT	55
14	M13F GCTGCTTCTGGCCTCTTTA	M13R GCTGTTTCAAATGCCTACCTCT	55
15	M13F TGAACATAGCCCTGTGTATG	M13R TTTTGTACACAACCTCTCTG	58
16	M13F AGACTTCTGCCCCAGATGA	M13R AACCACCAGCAACGTGATT	63

Forward primers have -21M13F tail attached for sequencing: TGTAACAGACGGCCAGT; reverse primers have M13R tail attached for sequencing: CAGGAAACGACTATGAC.

calcium binding domain of the E-cadherin protein; R732 is located at the intracellular border of the cytoplasmic domain of the molecule. Residue A298 is in the second calcium binding domain of the molecule and is conserved in all these species but *Xenopus*, which contains a conservative substitution of glycine for the alanine residue.

To confirm the theoretical prediction of a deleterious effect on protein function for the three identified E-cadherin germline missense mutations, functional assays including cell-cell adhesion and collagen invasion have been performed in vitro. CHO E-cadherin negative cells with epithelial origin have been used as cell model system and transfected to stably express the different E-cadherin germline mutations. To exclude clonal dependence of the results, at least two independent clones for each mutation have been used for the functional analysis; results have been discussed in comparison to what was observed for cells expressing the wild type protein. For the study, only clones expressing an equal amount of protein upon transfection were selected using quantitative Western blot analysis. All three mutants resulted in the expected 120 kDa band. Results for the functional characterisation are reported in table 4. All mutations dramatically affect the ability of E-cadherin to mediate cell-cell adhesion and suppress cell invasion, supporting their pathogenic role in gastric cancer.

Family ascertainment criteria and CDH1 screening

To determine the optimal inclusion criteria for families for CDH1 diagnostic screening, we assessed six different criteria for ascertainment of families and determined which ones identify families likely to benefit from CDH1 screening. Eight of the 15 (53%) families who meet criterion 1 (two or more documented cases of DGC in first degree relatives, with at least one diagnosed before age 50) had a CDH1 mutation; four of the 10 (40%) families who met our revised criterion 1A (two or more cases of GC, with at least one documented DGC diagnosed before the age of 50) and one family that met criterion 6 (one family member diagnosed with DGC and another with colon cancer) carried CDH1 mutations (table 1). The single family that met criterion 6 had a family member with a signet ring carcinoma of the colon, a cancer known to be associated with somatic loss of E-cadherin expression.²² The optimal criteria for CDH1 diagnostic screening, as determined in the present study, are fulfilment of criterion 1, or the less stringent criterion 1A. Insufficient families met criterion 2, so assessment of this criterion as a means of identifying families for CDH1 diagnostic screening could not be addressed using this sample set. No mutations were

identified in the family (F22) that, upon pathologic review, was demonstrated to have intestinal type gastric cancer.

Twelve of the 42 DGC families included women with breast cancers. Within the 25 families who met criteria 1 or 1A there were 17 women with breast cancer; of these three had confirmed lobular breast cancer and one ductal adenocarcinoma: the pathologic subtype of the other breast cancers is unknown. Within these 25 families there were 128 women who were either sisters or mothers of individuals with gastric cancer or sisters or mothers of obligate carriers for gastric cancer susceptibility. In the 12 criteria 1 or 1A families in whom a CDH1 mutation was identified, 12 breast cancers occurred amongst 75 at risk females only half of whom would be expected to carry mutations. These 12 breast cancers occurred in five CDH1 mutation positive families with five cases concentrated in family F11 (fig 2). Although insufficient genotyping and pathological data for a formal penetrance study are available, our results appear concordant with the previous calculated breast cancer risk of 39% in germline CDH1 mutation carriers. The five CDH1 mutations from the families with HDGC and breast cancers were distributed across the gene suggesting that no genotype-phenotype correlation is present.

DISCUSSION

A role for E-cadherin in tumour development is now well established,²³ since many human carcinomas such as skin, head and neck, lung, breast, thyroid, gastric, colon, and ovarian exhibit reduced E-cadherin expression relative to their normal cellular counterparts. Somatic loss of E-cadherin expression is seen in most diffuse gastric cancers and in lobular breast cancers, although expression is usually maintained in intestinal gastric cancers and ductal breast cancers.^{10 24 25}

In sporadic diffuse gastric cancers and lobular breast cancers, E-cadherin loss is associated with somatic point mutations of the E-cadherin gene, loss of heterozygosity, and/or promoter hypermethylation.^{10 12 22 26} The sequence of these events is unknown. In most carcinomas loss of E-cadherin is usually a late event associated with invasion and metastasis. In hereditary diffuse gastric cancers, however, E-cadherin loss is likely to be an early, and potentially an initiating event.

The genetic attributable risk for gastric cancer development is similar to that for breast and colorectal cancers.²⁷ As with these other cancers, there are families demonstrating autosomal dominant inheritance and also those that show clustering of gastric cancers for which the etiology is likely multifactorial.²⁷ Family history is a positive risk factor for

Table 4 Functional characterisation of missense mutations

	Aggregation		Invasion
	Particle diameter (μm) T ₀	Particle diameter (μm) T ₃₀	Invasion index (%)
Mock cells*	16.52	19.25	10.8 \pm 1.2
Wild type	17.95	1067.00	1.2 \pm 0.2
A298T	21.60	26.21	13.5 \pm 0.8
W409R	20.00	32.21	22.05 \pm 0.7
R732Q	22.08	29.22	13.2 \pm 1.1

*A heterogeneous cell population characteristic of cells transfected with the empty vector.

both diffuse and intestinal gastric cancers.⁷ The heritable factors that account for the increased risk in families of index cases include both highly penetrant mutations as well as polymorphisms that may modify host–environment interactions.^{27–28} Autosomal dominant gastric cancer is both clinically and genetically heterogeneous. Most families show only diffuse cancers.⁷ Gastric carcinomas are seen in families with germline p53 mutations,²⁹ and hereditary non-polyposis colon cancer (HNPCC).²⁹ However, 85% of HNPCC associated gastric cancers are of the intestinal type.^{30–31} Gastric cancer is also seen in both Peutz-Jeghers syndrome (PJS) and familial adenomatous polyposis (FAP). In PJS, hamartomatous polyps in the stomach occur in approximately 24% of patients.^{32–33} However, the risk of gastric cancer is small. Although gastric adenomatous polyps occur in about 10% of individuals with FAP, the risk of gastric cancer is small.^{33–35}

In 1998, Parry Guilford and colleagues described germline truncating E-cadherin mutations in three Maori families with autosomal dominant diffuse gastric cancer.⁸ Soon afterward, we reported similar mutations in three families of Northern European origin.⁹ E-cadherin acts as a tumour suppressor gene in these families, with the loss of expression of the wild type E-cadherin allele usually occurring through promoter hypermethylation.²⁶ To date, including this study, 27 truncating E-cadherin mutations have been reported, only one of which has been found twice.^{9–10, 36–42} These mutations are present in approximately one third of families with two or more first degree relatives having confirmed cases of diffuse gastric cancer.⁷ A penetrance analysis of E-cadherin mutations in 11 families showed an estimated cumulative risk of gastric cancer by age 80 years of 67% for men (95% confidence interval (95% CI) 39 to 99) and 83% for women (95% CI 58 to 99).⁴³

We have screened a series of 42 DGC families for germline mutations in the CDH1 gene. Thirteen families (31% overall) had either overt loss of function mutations or missense mutations likely to have functional consequences for the E-cadherin protein. Functional assays have demonstrated that all missense mutations do not retain the wild type E-cadherin functions of cell adhesion and suppression of invasion. All of the CDH1 mutations observed in these families are novel, underlining the absence of founder effect previously noted for CDH1 mutations underlying this familial cancer.^{9–10}

When a detailed comparison of CDH1 mutation status *v* family ascertainment criteria is performed it is apparent, however, that families that have CDH1 mutations are those with a strong family history of early onset diffuse gastric cancer. Some 48% of such families had germline CDH1 mutations in this study. The nature of the families in this sample set makes it difficult to determine whether a strong family history alone (in the absence of early onset disease; criterion 2) also correlates with the presence of CDH1 mutations. The only family (F7) with an E-cadherin mutation (W409R) that does not meet criteria 1 or 1A, included an individual with a histologically defined signet ring cell cancer of the colon (SRCC). We have previously

observed an SRCC in a 35 year old male with another CDH1 missense mutation (Thr340Ala).¹⁰ Signet ring carcinomas of the colon are extremely rare, representing nine of 3000 (0.003%) of colon cancers in a series of colon cancers from Singapore,⁴⁴ 27 of 2589 (0.01%) cases from Canada,⁴⁵ and 24 of 323 (7%) colon cancer from the USA.⁴⁶ The higher proportion of signet ring carcinomas in the latter study reflect that this study cohort was derived from a clinical trial versus being population based. Although up to 50% of SRCCs have microsatellite instability, a feature associated with HNPCC, little is known about the pathogenesis of microsatellite stable cases other than loss of E-cadherin expression.^{22–46} The occurrence of this rare subtype of colon cancer in two CDH1 mutation positive families is insufficient to prove an association. However, given the known role of loss of somatic E-cadherin expression in SRCCs and the reported presence of intramucosal signet ring carcinoma, a lesion previously described in the prophylactic gastrectomy specimens of germline CDH1 mutation carriers, a role for CDH1 germline mutation in the susceptibility to SRCC is feasible⁴⁵ and warrants further investigation.

Our study and others^{5–18} show that a single individual with early onset DGC without a strong family history is unlikely to carry a CDH1 germline mutation. Our current data set does not contain enough families with both lobular breast cancer and DGC to determine if CDH1 screening is advisable for such families.

Breast cancer was reported in the first E-cadherin associated HDGC families,⁸ but the histologic type was not determined. Keller⁶ reported a family in which a germline truncating mutation carrier had a lobular breast cancer. In sporadic lobular breast cancers, loss of E-cadherin expression is commonly seen and somatic mutations are frequently seen in combination with loss of heterozygosity at the E-cadherin locus. In the 11 families included in the IGCLC penetrance study,⁴⁰ nine cases of breast cancer were reported. For women, the cumulative risk of breast cancer was 39% (95% CI 12 to 84). Lobular cancer was present in all five cases where pathology was available. No CDH1 mutations were identified in the germline DNA of 65 women with lobular breast carcinoma in situ (LCIS),⁴⁷ six families with both breast and gastric cancers,⁴⁷ or in 13 patients with familial lobular breast cancer.²⁴ In this study, 17 cases of breast cancer occurred in families with germline E-cadherin mutations. However, only 4/17 cases of the breast cancers could be confirmed pathologically. Of these, three were the lobular type. These data are supportive but insufficient to conclusively prove an association between lobular breast cancer and germline E-cadherin mutations. Since breast cancers were also seen in the CDH1 negative families it is possible that the cancer susceptibility in these families may be caused by CDH1 mutations missed by bi-directional sequencing or mutation events in genes that, like CDH1, have relevance for both DGC and LBC.

These results are key for the development of optimal guidelines for the management of individuals within HDGC families. At present, the best preventive treatment for HDGC

is prophylactic gastrectomy, a procedure that is life saving but has an associated high morbidity and mortality rate. The importance of identifying the genetic basis of cancer susceptibility in HDGC families has been underscored by the recent observation of early gastric cancers in 10 prophylactic gastrectomy samples from germline E-cadherin mutation carriers.^{48–49} The findings suggest that prophylactic gastrectomy is currently the best treatment for germline mutation carriers and that current endoscopic screening techniques are inadequate. In 50–70% of HDGC families, cancer susceptibility is caused by unknown genetic factors and so predictive testing is not possible at present. Missense mutations remain problematic for clinical management because, without both extensive family data and functional data, it is difficult to predict the pathogenicity of a missense mutation. In the absence of such data, it may not be appropriate to use E-cadherin missense mutation status to segregate risk within an HDGC family.

A total of 29 families were found not to have a mutation in the coding region of the E-cadherin gene. These families could carry a CDH1 mutation for which our assay is insensitive, such as a small intragenic deletion involving one or more exons. However, it may be more likely that most of these families bear mutations in other HDGC susceptibility genes that remain to be discovered. This view is consistent with previous observations of genetic^{50–51} and linkage³⁶ heterogeneity in this disease. Unfortunately only a minority of these families are of adequate size to permit linkage mapping. Identification of novel genes that underlie HDGC will therefore rely on combination strategies that employ candidate gene screening, perhaps in combination with linkage mapping in those few families of sufficient size. The 29 CDH1 mutation negative families identified in this study represent a resource for the identification of novel HDGC genes. Identification of such genes will substantially improve the diagnostic opportunities for at risk individuals in such families, in addition to providing information about the biochemical pathways that underlie this disease.

In conclusion, germline CDH1 mutations are present in close to 50% of families in which there is both a documented DGC in an individual diagnosed at age 50 or younger and a family history of gastric cancer. Testing individuals who do not meet these criteria is unlikely to yield CDH1 mutations.

ACKNOWLEDGEMENTS

We are very grateful to the families who participated in this study. This work was supported by Genome Canada and Genome British Columbia. David Huntsman is the recipient of a Michael Smith Foundation for Health Research Career Investigator Award.

Authors' affiliations

A R Brooks-Wilson, S Leach, Y S N Butterfield, J Jeyes, J Schinas, Genome Sciences Centre, British Columbia Cancer Agency, 600 W. 10th Avenue, Vancouver, BC, Canada V5Z 4E6

A R Brooks-Wilson, B MacGillivray, Department of Medical Genetics, University of British Columbia, Vancouver, BC, Canada V6H 3N1

P Kaurah, M Kelsey, B MacGillivray, D Huntsman, Hereditary Cancer Program, British Columbia Cancer Agency, Vancouver, BC, Canada V5Z 4E6

G Suriano, P Ferreira, M J Oliveira, R Seruca, Instituto de Patologia e Imunologia Molecular da Universidade do Porto (IPATIMUP), 4200 Porto, Portugal

J Senz, Prostate Centre, Vancouver General Hospital, Vancouver, BC, Canada V6H 3Z6

N Grehan, Department of Oncology, University of Cambridge and Wellcome Trust Centre for Molecular Mechanisms in Disease/Cambridge Institute for Medical Research, Wellcome Trust/MRC Building Level 6, Cambridge CB2 2XY, UK

J Bacani, Samuel Lunenfeld Research Institute, University of Toronto, Toronto, ON, Canada M5G 1X5

P MacLeod, M Micek, Medical Genetics, Victoria General Hospital, Victoria, BC, Canada V8Z 6R5

J Ford, Divisions of Oncology and Medical Genetics, Stanford University Medical Centre, Stanford, CA 94305, USA

W Foulkes, Program in Cancer Genetics, Departments of Oncology and Human Genetics, McGill University, Montreal, QC, Canada H3G 1A4

K Australie, Division of Medical Genetics, McGill University, Montreal, QC, Canada H3G 1A4

C Greenberg, M LaPointe, Section of Genetics and Metabolism, Children's Hospital, Winnipeg, MB, Canada R3A 1R9

C Gilpin, S Nikkel, Department of Genetics, Children's Hospital of Eastern Ontario, Ottawa, ON, Canada K1H 8L1

D Gilchrist, Medical Genetics Clinic, University of Alberta, Edmonton, AB, Canada T6G 2R7

R Hughes, Departments of Oncology and Medical Genetics, University of Calgary, Calgary, AB, Canada T2N 4N1

C E Jackson, Scott and White Clinic, Temple, TX 76508, USA

K G Monaghan, Department of Medical Genetics, Henry Ford Hospital, Detroit, MI 48202, USA

S Gallinger, Familial Gastrointestinal Cancer Registry, Mount Sinai Hospital, Toronto, ON, Canada M5G 1X5

D Huntsman, Department of Pathology and Laboratory Medicine, University of British Columbia, Vancouver, BC, Canada V6T 2B5

Conflict of interest: none declared.

*Please note that correspondence can be addressed to both the authors indicated.

REFERENCES

- 1 **Karpeh MS,** Kelsen DP, Tepper JE. Cancer of the stomach. In: DeVita VT, Hellman S, Rosenberg SA, eds. *Cancer: principles and practice of oncology*. 6th ed. Philadelphia: Lippincott, Williams and Wilkins, 2001:1092–126.
- 2 **Lauren P.** The two histological main types of gastric carcinomas: diffuse and so-called intestinal-type carcinoma. *Cancer* 1965;**70**:50–5.
- 3 **Machado JC,** Soares P, Carneiro F, Rocha A, Beck S, Blin N, Bex G, Sobrinho-Simoes M. E-cadherin gene mutations provide a genetic basis for the phenotypic divergence of mixed gastric carcinomas. *Lab Invest* 1999;**79**:459–65.
- 4 **Stemmermann GN,** Nomura AM, Kolonel LN, Goodman MT, Wilkens LR. Gastric carcinoma: pathology findings in a multiethnic population. *Cancer* 2002;**95**:744–50.
- 5 **Stone J,** Bevan S, Cunningham D, Hill A, Rahman N, Peto J, Marossy A, Houlston RS. Low frequency of germline E-cadherin mutations in familial and nonfamilial gastric cancer. *Br J Cancer* 1999;**79**:1935–37.
- 6 **Keller G,** Vogelsang H, Becker I, Hutter J, Ott K, Candius S, Grundei T, Becker KF, Mueller J, Siewert JR, Hofler H. Diffuse type gastric and lobular breast carcinoma in a familial gastric cancer patient with an E-cadherin germline mutation. *Am J Pathol* 1999;**155**:337–42.
- 7 **Caldas C,** Carneiro F, Lynch HT, Yokota J, Wiesner GL, Powell SM, Lewis FR, Huntsman DG, Pharoah PD, Jankowski JA, MacLeod P, Vogelsang H, Keller G, Park KG, Richards FM, Maher ER, Gayther SA, Oliveira C, Grehan N, Wight D, Seruca R, Roviello F, Ponder BA, Jackson CE. Familial gastric cancer: overview and guidelines for management. *J Med Genet* 1999;**36**:873–80.
- 8 **Guilford P,** Hopkins J, Harraway J, McLeod M, McLeod N, Harawira P, Taite H, Scoular R, Miller A, Reeve AE. E-cadherin germline mutations in familial gastric cancer. *Nature* 1998;**392**:402–5.
- 9 **Gayther SA,** Goringe KL, Ramus SJ, Huntsman D, Roviello F, Grehan N, Machado JC, Pinto E, Seruca R, Halling K, MacLeod P, Powell SM, Jackson CE, Ponder BA, Caldas C. Identification of germ-line E-cadherin mutations in gastric cancer families of European origin. *Cancer Res* 1998;**58**:4086–89.
- 10 **Oliveira C,** Bordin MC, Grehan N, Huntsman D, Suriano G, Machado JC, Kiviluoto T, Aaltonen L, Jackson CE, Seruca R, Caldas C. Screening E-cadherin in gastric cancer families reveals germline mutations only in hereditary diffuse gastric cancer kindred. *Hum Mutat* 2002;**19**:510–17.
- 11 **Takeichi M.** Morphogenetic roles of classic cadherins. *Curr Opin Cell Biol* 1995;**7**:619–27.
- 12 **Machado JC,** Oliveira C, Carvalho R, Soares P, Bex G, Caldas C, Seruca R, Carneiro F, Sobrinho-Simoes M. E-cadherin gene (CDH1) promoter methylation as the second hit in sporadic diffuse gastric carcinoma. *Oncogene* 2001;**20**:1525–8.
- 13 **Bex G,** Cleton-Jansen AM, Nallet F, de Leeuw WJ, van de Vijver M, Cornelisse C, van Roy F. E-cadherin is a tumour/invasion suppressor gene mutated in human lobular breast cancers. *EMBO J* 1995;**14**:6107–15.
- 14 **Ewing B,** Green P. Base-calling of automated sequencer traces using Phred. II. Error probabilities. *Genome Res* 1998;**8**:186–94.
- 15 **Ewing B,** Hillier L, Wendl MC, Green P. Base-calling of automated sequencer traces using phred. I. Accuracy assessment. *Genome Res* 1998;**8**:175–85.
- 16 **Nickerson DA,** Tobe VO, Taylor SL. PolyPhred: automating the detection and genotyping of single nucleotide substitutions using fluorescence-based resequencing. *Nucleic Acids Res* 1998;**25**:2745–51.
- 17 **Gordon D,** Abajian C, Green P. Consed: a graphical tool for sequence finishing. *Genome Res* 1998;**8**:195–202.
- 18 **Suriano G,** Oliveira C, Ferreira P, Machado JC, Bordin MC, De Wever O, Bruyneel EA, Moguilevsky N, Grehan N, Porter TR, Richards FM, Hruban R, Roviello F, Huntsman D, Mareel M, Carneiro F, Caldas C, Seruca R.

- Identification of CDH1 germline missense mutations associated with functional inactivation of the E-cadherin protein in young gastric cancer probands. *Hum Mol Genet* 2003;**12**:575–82.
- 19 **Suriano G**, Mulholland D, de Wever O, Ferreira P, Mateus AR, Bruyneel E, Nelson CC, Mareel MM, Yokota J, Huntsman D, Seruca R. The intracellular E-cadherin germline mutation V832 M lacks the ability to mediate cell–cell adhesion and to suppress invasion. *Oncogene* 2003;**22**:5716–9.
 - 20 **Berx G**, Cleton-Jansen AM, Strumane K, de Leeuw WJ, Nollet F, van Roy F, Cornelisse C. E-cadherin is inactivated in a majority of invasive human lobular breast cancers by truncation mutations throughout its extracellular domain. *Oncogene* 1996;**13**:1919–25.
 - 21 **Ng PC**, Henikoff S. Accounting for human polymorphisms predicted to affect protein function. *Genome Res* 2002;**12**:436–46.
 - 22 **Darwanto A**, Kitazawa R, Maeda S, Kitazawa S. MeCP2 and promoter methylation cooperatively regulate E-cadherin gene expression in colorectal carcinoma. *Cancer Sci* 2003;**94**:442–7.
 - 23 **Wijnhoven BP**, Dinjens WN, Pignatelli M. E-cadherin-catenin cell-cell adhesion complex and human cancer. *Br J Surg* 2000;**87**:992–1005.
 - 24 **Salahshor S**, Haixin L, Huo H, Kristensen VN, Loman N, Sjoberg-Margolin S, Borg A, Borresen-Dale AL, Vorechovsky I, Lindblom A. Low frequency of E-cadherin alterations in familial breast cancer. *Breast Cancer Res* 2001;**3**:199–207.
 - 25 **Becker KF**, Atkinson MJ, Reich U, Becker I, Nekarda H, Siewert JR, Hofer H. E-cadherin gene mutations provide clues to diffuse type gastric carcinomas. *Cancer Res* 1994;**54**:3845–52.
 - 26 **Grady WM**, Willis J, Guilford PJ, Dunbier AK, Toro TT, Lynch H, Wiesner G, Ferguson K, Eng C, Park JG, Kim SJ, Markowitz S. Methylation of the CDH1 promoter as the second genetic hit in hereditary diffuse gastric cancer. *Nat Genet* 2000;**26**:16–7.
 - 27 **Lichtenstein PHN**, Verkasalo PK, Iliadou A, Kaprio J, Koskenvuo M, Pukkala E, Skytthe A, Hemminki K. Environmental and heritable factors in the causation of cancer—analyses of cohorts of twins from Sweden, Denmark, and Finland. *N Engl J Med* 2000;**343**:78–85.
 - 28 **El-Omar EM**, Carrington M, Chow WH, McColl KE, Bream JH, Young HA, Herrera J, Lissowska J, Yuan CC, Rothman N, Lanyon G, Martin M, Fraumeni JF Jr, Rabkin CS. Interleukin-1 polymorphisms associated with increased risk of gastric cancer. *Nature* 2000;**404**:398–402.
 - 29 **Shimura K**, Kohno T, Takahashi M, Sasaki A, Ochiai A, Guilford P, Hunter A, Reeve AE, Sugimura H, Yamaguchi N, Yokota J. Familial gastric cancer: clinicopathological characteristics, RER phenotype and germline p53 and E-cadherin mutations. *Carcinogenesis* 1999;**20**:1127–31.
 - 30 **Aarnio M**, Salovaara R, Aaltonen LA, Mecklin JP, Jarvinen HJ. Features of gastric cancer in hereditary non-polyposis colorectal cancer syndrome. *Int J Cancer* 1997;**74**:551–5.
 - 31 **Heinimann K**, Muller H, Weber W, Scott RJ. Disease expression in Swiss hereditary non-polyposis colorectal cancer (HNPCC) kindreds. *Int J Cancer* 1997;**74**:281–5.
 - 32 **Giardiello FM**, Welsh SB, Hamilton SR, Offerhaus GJ, Gittelsohn AM, Booker SV, Krush AJ, Yardley JH, Luk GD. Increased risk of cancer in the Peutz-Jeghers syndrome. *N Engl J Med* 1987;**316**:1511–4.
 - 33 **Boardman L**, Thibodeau SN, Schaid DJ, Lindor NM, McDonnell SK, Burgart LJ, Ahlquist DA, Podratz KC, Pittelkow M, Hartmann LC. Increased risk for cancer in patients with Peutz-Jeghers syndrome. *Ann Intern Med* 1998;**128**:896–9.
 - 34 **Bulow S**, Alm T, Fausa O, Hultcrantz R, Jarvinen H, Vasen H, Bulow S, Alm T, Fausa O, Hultcrantz R, Jarvinen H, Vasen H. Duodenal adenomatosis in familial adenomatous polyposis. DAF Project Group. *Int J Colorectal Dis* 1995;**10**:43–6.
 - 35 **Wallace MH**, Phillips RK. Upper gastrointestinal disease in patients with familial adenomatous polyposis. *Br J Surg* 1998;**85**:742–50.
 - 36 **Humar B**, Toro T, Graziano F, Muller H, Dobbie Z, Kwang-Yang H, Eng C, Hampel H, Gilbert D, Winship I, Parry S, Ward R, Findlay M, Christian A, Tucker M, Tucker K, Merriman T, Guilford P. Novel germline CDH1 mutations in hereditary diffuse gastric cancer families. *Hum Mutat* 2002;**19**:518–25.
 - 37 **Richards FM**, McKee SA, Rajpar MH, Cole TR, Evans DG, Jankowski JA, McKeown C, Sanders DS, Maher ER. Germline E-cadherin gene (CDH1) mutations predispose to familial gastric cancer and colorectal cancer. *Hum Mol Genet* 1999;**8**:607–10.
 - 38 **Guilford PJ**, Hopkins JB, Grady WM, Markowitz SD, Willis J, Lynch H, Rajput A, Wiesner GL, Lindor NM, Burgart LJ, Toro TT, Lee D, Limacher JM, Shaw DW, Findlay MP, Reeve AE. E-cadherin germline mutations define an inherited cancer syndrome dominated by diffuse gastric cancer. *Hum Mutat* 1999;**14**:249–55.
 - 39 **Dussaulx-Garin L**, Blayau M, Pagenault M, Le Berre-Heresbach N, Raoul JL, Campion JP, David V, Bretagne JF. A new mutation of E-cadherin gene in familial gastric linitis plastica cancer with extra-digestive dissemination. *Eur J Gastroenterol Hepatol* 2001;**3**:711–5.
 - 40 **Yoon KA**, Ku JL, Yang HK, Kim WH, Park SY, Park JG. Germline mutations of E-cadherin gene in Korean familial gastric cancer patients. *J Hum Genet* 1999;**44**:177–80.
 - 41 **Jonsson BA**, Bergh A, Stattin P, Emmanouelsson M, Gronberg H. Germline mutations in E-cadherin do not explain association of hereditary prostate cancer, gastric cancer and breast cancer. *Int J Cancer* 2002;**20**:838–43.
 - 42 **Yabuta T**, Shimura K, Tani M, Yamaguchi S, Yoshimura K, Katai H, Nakajima T, Mochiki E, Tsujinaka T, Takami M, Hirose K, Yamaguchi A, Takenoshita S, Yokota J. E-cadherin gene variants in gastric cancer families whose probands are diagnosed with diffuse gastric cancer. *Int J Cancer* 2002;**10**:434–41.
 - 43 **Pharoah PD**, Guilford P, Caldas C. International Gastric Cancer Linkage Consortium. Incidence of gastric cancer and breast cancer in CDH1 (E-cadherin) mutation carriers from hereditary diffuse gastric cancer families. *Gastroenterology* 2001;**121**:1348–53.
 - 44 **Ooi BS**, Ho YH, Eu KW, Seow Choen F. Primary colorectal signet-ring cell carcinoma in Singapore. *ANZ J Surg* 2001;**71**:703–6.
 - 45 **Mai KT**, Isotalo PA, Guindi M, Burns BF, Parks W. Intestinal epithelial lesions associated with signet ring cell carcinoma of the colon and small intestine. *Pathology* 2002;**34**:51–6.
 - 46 **Alexander J**, Watanabe T, Wu TT, Rashid A, Li S, Hamilton SR. Histopathological identification of colon cancer with microsatellite instability. *Am J Pathol* 2001;**58**:527–35.
 - 47 **Rahman N**, Stone JG, Coleman G, Gusterson B, Seal S, Marossy A, Lakhani SR, Ward A, Nash A, McKinna A, A'Hern R, Stratton MR, Houlston RS. Lobular carcinoma in situ of the breast is not caused by constitutional mutations in the E-cadherin gene. *Br J Cancer* 2000;**82**:568–70.
 - 48 **Huntsman DG**, Carneiro F, Lewis FR, MacLeod PM, Hayashi A, Monaghan KG, Maung R, Seruca R, Jackson CE, Caldas C. Early gastric cancer in young, asymptomatic carriers of germ-line E-cadherin mutations. *N Engl J Med* 2001;**344**:1904–9.
 - 49 **Chun YS**, Lindor NM, Smyrk TC, Petersen BT, Burgart LJ, Guilford PJ, Donohue JH. Germline E-cadherin gene mutations. Is prophylactic total gastrectomy indicated? *Cancer* 2001;**92**:181–7.
 - 50 **Bevan S**, Houlston RS. Genetic predisposition to gastric cancer. *Q J Med* 1999;**92**:5–10.
 - 51 **Kaneda A**, Kaminishi M, Yanagihara K, Sugimura T, Ushijima T. Identification of silencing of nine genes in human gastric cancers. *Cancer Res* 2002;**62**:6645–50.