

The use of genotype-phenotype correlations in mutation analysis for the long QT syndrome

I M Van Langen, E Birnie, M Alders, R J Jongbloed, H Le Marec, A A M Wilde

J Med Genet 2003;40:141-145

The autosomal dominant form of the congenital long QT syndrome (LQTS or Romano-Ward syndrome) is a disease of disturbance of repolarisation of cardiac myocytes secondary to malfunctioning ion channels, potentially leading to ventricular arrhythmias. The estimated prevalence is 1 in 5000-7000.¹

LQTS is diagnosed by analysis of surface electrocardiograms, clinical presentation, and family history.² Cardiac events in first and second degree relatives of LQTS patients occur in 6-13% of cases.³ Thirty percent of mutation carriers do not have a prolonged QT interval, but are still at risk for complications.^{4,5} Beta blockers and adjustments in life style are effective in most LQTS patients.⁶

Up to now, five LQTS genes (and one locus on chromosome 4) have been identified: *KCNH2*, *KCNQ1*, *SCN5A*, *KCNE1*, and *KCNE2* on chromosomes 7, 11, 3, 21, and 21, respectively. At present, the genotype has been identified in 50-70% of patients. Most patients have a private (missense) mutation in *KCNH2* or *KCNQ1*.⁷

Diagnostic screening of all five LQTS associated genes at once potentially leads to relatively fast mutation detection but is very labour intensive and costly. Sequential mutational analysis, starting with the gene that accounts for the largest percentage of mutations based on published gene prevalences (*KCNH2*, 45%), has the same disadvantages, albeit to a lesser extent.⁷ In most patients, a mutation will not be detected at the first attempt, so in most cases at least two genes have to be screened to detect the disease causing mutation. This is a major drawback for diagnosis of mutations in LQTS.⁸⁻¹⁰ Nevertheless, several commercial diagnostic services exist.¹¹

Distinct genotype-phenotype correlations have been reported in LQTS. Age of onset, symptom related triggers, the ST-T segment morphology of the ECG, and the response to drugs are all linked to the aberrant gene.¹²⁻¹⁹ In short, *KCNQ1* mutations are associated with an early age of onset, triggers are exercise, swimming, and emotion, and ECGs are characterised by normal or broad based T waves. Patients with *KCNH2* mutations have an older age of onset, triggers can be arousal, noise, emotion, exercise, or rest, and ECGs show low amplitude, bifid T waves. In patients with *SCN5A* mutations, the age of onset is relatively late, triggers are quiescence and sleep, and ECGs are characterised by late onset of peaked, bifid, or asymmetrical T waves. Patients with *KCNQ1* and (to a lesser extent) with *KCNH2* mutations exhibit good responses to beta blockade, while patients with *SCN5A* mutations may need other treatment (for example, pacemaker, internal defibrillator).

In this study, we prospectively investigated whether the success rate of mutation detection in the genes first elected for analysis in LQTS index patients can be raised if known genotype-phenotype correlations are used.

MATERIALS AND METHODS

Subjects

Forty consecutive, unrelated LQTS patients originating from The Netherlands and Belgium, who were referred to the diag-

Key points

- Identification of causative mutations in index patients with long QT syndrome is important for treatment decisions and to enable cascade screening in relatives.
- Mutation analysis is time consuming and costly, because of extensive genetic heterogeneity.
- Clear genotype-phenotype correlations in long QT syndrome have been described.
- The efficiency of mutation analysis is greatly enhanced if it is directed by phenotypic information (ECGs, clinical data). In 90% of patients so genotyped, the mutation is detected in the first eligible gene.
- If only the most eligible gene is screened, the disease causing mutation is detected in 70% of all index patients (78% are detected if all five genes are screened).
- With this relatively cheap and fast way of DNA mutation analysis, referral of more LQTS patients for mutation analysis is encouraged. This will lead to timely identification and prophylactic treatment of many young people at risk of dying suddenly.

nostic centres in Amsterdam and Maastricht, were included in this study. Diagnosis of LQTS was based on accepted criteria.² None of the patients was involved in earlier studies on genotype-phenotype correlations.¹⁵ Informed consent was obtained from all participants or their guardians.

Clinical investigations

Clinical data on symptom related triggers, age of onset of symptoms, and ECG recordings of the index patient and, if possible, his or her relatives were collected. Only the information on relatives available at the time of referral was used. If an index patient had died without leaving an ECG recording (eight cases), clinical data of the index patient and ECG recordings of a clearly affected first degree relative were used. ECG analysis was performed by calculation of QT intervals corrected for heart rate (QT_c) and interpretation of the morphology of the ST-T segments.

DNA analysis

DNA analysis was performed on DNA isolated from blood samples collected from living LQTS patients or on stored DNA of dead patients. If no stored DNA of a dead patient was available (six cases), a blood sample of a clearly affected first degree relative was used. DNA extraction, polymerase chain reaction (PCR) amplification, single strand conformation polymorphism (SSCP), or denaturing high performance liquid chromatography (DHPLC) analysis and sequencing of aberrant conformers or elution profiles by using fluorescent dye terminators were performed, as described elsewhere.¹⁵

One of the authors (AW), a cardiologist familiar with LQTS, decided the order of genes to be screened (choosing from the three major genes, *KCNH2*, *KCNQ1*, and *SCN5A*) on the basis of clinical data and knowledge of prevalence and genotype-phenotype correlations. For research purposes, *KCNE1* and *KCNE2* were screened in every patient. Both are small genes, coding for auxiliary subunits of the *KCNQ1* and *KCNH2* genes. Pathogenic and non-pathogenic sequence alterations were distinguished based on published criteria, including the absence of the presumed mutation in 100 control alleles.²⁰ Analysis of more genes after finding an aberration in the first assigned one, *KCNQ1*, was performed in one symptomatic LQTS patient of Turkish ancestry, because no control DNA from the Turkish population was available to exclude that this missense mutation was a polymorphism.

Added value of phenotypic data

The added value of phenotypic data was evaluated independently by a second cardiologist (HM), not personally involved in the management of the study population and therefore initially blinded for information on ages of onset, symptom related triggers, and family data of the patients. The study was conducted as follows. First, ECGs and patient variables that potentially influence ECG morphology (present age, sex, and, if applicable, data on medications and therapy) were presented and the cardiologist was asked which LQTS gene was most likely to be mutated. Second, additional data on the age of onset, symptom related triggers and, if available, ECGs and medical histories of relatives were presented and the cardiologist again was asked which LQTS gene was most likely to be mutated.

As reference, we used the prevalences of gene mutations in the largest LQTS cohort available, consisting of 262 European and American patients. In this study, the molecular diagnosis was established in 68% of the patients: *KCNH2* 45%, *KCNQ1* 42%, *SCN5A* 8%, *KCNE1* 3%, and *KCNE2* 2%.⁷

Screening strategies

The impact of the use of phenotypic information was evaluated in terms of the percentages of cost reductions and

yields of three screening strategies each taking the shortest time possible for results to be available: (1) screening all five genes at once in all patients, (2) screening the most eligible gene (*KCNH2*) only, based on published prevalences, and (3) screening the most eligible gene in each patient, based on phenotypic information.

Statistical analyses

The added value of ECG morphology in assignment of the affected gene was calculated as the proportion of correct predictions of the affected gene after ECG data had been presented compared to the proportion of *KCNH2* mutations in the reference population. The added value of all phenotypic data (ECGs, ages of onset, symptom related triggers, family data) was calculated as the proportion of correctly predicted mutated genes after supply of all phenotypic information compared to the prevalence of *KCNH2* mutations in the reference population. Both comparisons were tested statistically with the non-parametric binomial test.

The added value of information on ages of onset and symptom related triggers and family data in addition to ECG data only was calculated as the proportion of correct predictions after supply of all phenotypic information compared to that proportion of ECG data only. Comparisons in these paired proportions of correctly predicted mutated genes were tested with the McNemar test.

The assessment of the inter-observer agreement in predicting the mutated gene after presentation of all phenotypic information was used to test the reproducibility of prediction method and evaluated with the (unweighted) kappa statistic.

Finally, the effect of the availability of family data on the proportion of correctly predicted mutated genes was evaluated with the χ^2 test (two sided); p values <0.05 were considered significant.

RESULTS

Patients

There were 28 female and 12 male index patients, all with normal hearing. The mean age of onset of symptoms was 16.7

Table 1 Clinical characteristics, predicted genes, and genotypes of LQTS patients

Characteristic	Genotype*			
	<i>KCNQ1</i> (n=10)	<i>KCNH2</i> (n=18)	<i>SCN5A</i> (n=3)	No mutation (n=9)
Age of onset†				
0–9 y	5††	3§§	–	2
>9 y	5**/††	15	3	7
Triggers‡				
Exercise	9††/††	6	–	5
Swimming	5††	–	–	2
Emotion	2††/††	4	–	–
Arousal§	–	10	–	2
Quiescence	1**	6	3	2
Other	–	2§§	–	1
ECG morphology				
<i>KCNQ1</i> -like	8**	4	1	3
<i>KCNH2</i> -like	1††	14§§	1	6
<i>SCN5A</i> -like	1††	–	1	–
Predicted gene to be mutated¶				
<i>KCNQ1</i>	10**/††/††	1	–	4
<i>KCNH2</i>	–	17§§	2	4
<i>SCN5A</i>	–	–	1	1

*Based on mutation analysis.

†0–9 y: *KCNQ1* more probable, >9 y: *KCNH2* or *SCN5A* probable, but other criteria more important for assignment.

‡More than one trigger/patient is possible.

§Including noise.

¶Based on all phenotypic information.

**Including one compound *KCNQ1/SCN5A* mutation carrier.

††Including one compound heterozygous *KCNQ1* mutation carrier.

‡‡Including one homozygous *KCNQ1* mutation carrier.

§§Including one homozygous *KCNH2* mutation carrier.

Table 2 Mutations in 40 LQTS patients

KCNQ1	KCNH2	SCN5A
M159sp*	C64Y	Q692K§
G168R	L87P	A1330T
Y184S	G193 fs/136	I1768V
R259C	L200 fs/144†	1795insD
G292D*	210insL, T216 fs/120	
G314S	P251 fs/107	
Y315S	R582C‡	
S373P	G604S	
W379S	T613M	
R519C	V625E	
R562M§	F640L	
	M645L	
	S649L	
	E698X	
	R783 fs/24	
	R863X	
	P872 fs/4	

*Compound heterozygous.
†Homozygous.
‡In two patients.
§Both mutations in one patient.

years (SD 10.4) (range 0 (symptoms starting in utero) to 44 years). In three patients, the triggers for cardiac events were unknown, 20 patients reported one trigger, 14 patients had two, and three patients had three (table 1). ECGs and/or clinical data were available from family members of 29 index patients.

DNA findings

After screening a maximum of five LQTS related genes, the genotype could be determined in 31 (78%) patients, comparable to the yield in the reference group (table 2).⁷ Twenty-seven patients had heterozygous mutations, two patients were homozygous for mutations in *KCNQ1* and *KCNH2* respectively, and one was compound heterozygous for two mutations in *KCNQ1*. After detecting the *KCNQ1* mutation in a patient of

Turkish ancestry, a second missense mutation in *SCN5A* was determined. Neither presumed mutation has been reported previously and both were inherited from the father. In 28 patients, a mutation was depicted in the initially assigned gene (70%).

Added value of phenotypic data

Using ECG data exclusively, 74% (23/31, 95% CI 58 to 91) of the genotyped cases were predicted correctly, a significant increase compared to the prevalence of *KCNH2* mutations in the reference population (45%) ($p < 0.001$).

By complementing ECG data with information on age of onset, symptom related triggers, and data on relatives, 90% (28/31, 95% CI 74 to 97) of all genotyped cases were predicted correctly (fig 1). The proportion of correct predictions was increased significantly compared to the prevalence of *KCNH2* mutations in the reference population ($p < 0.001$) and was considerably higher than if only ECG information was used (90% v 74%, $p = 0.063$).

After presentation of all phenotypic data, the correct prediction rate was 87% for cardiologist AW and 90% for cardiologist HM. The inter-observer agreement was good ($\kappa = 0.68$, $p < 0.0001$), which supports the reproducibility of this prediction method.

The availability of family data did not increase the proportion of correct predictions (χ^2 test $p = 0.61$ for availability of ECGs and $p = 0.52$ for availability of all data).

Screening strategies

Screening all five genes at once in all index patients results in the optimal yield of 78% but is very labour intensive and expensive. While the use of resources is considerably reduced if only the most eligible gene based on prevalences in the reference group is screened, the yield also drops significantly (being only 45% in our study population). However, if the one most eligible gene based on individual phenotypic information is screened in all patients, the total yield is only reduced by 8% (to 70%), while labour and cost are reduced by 80%.

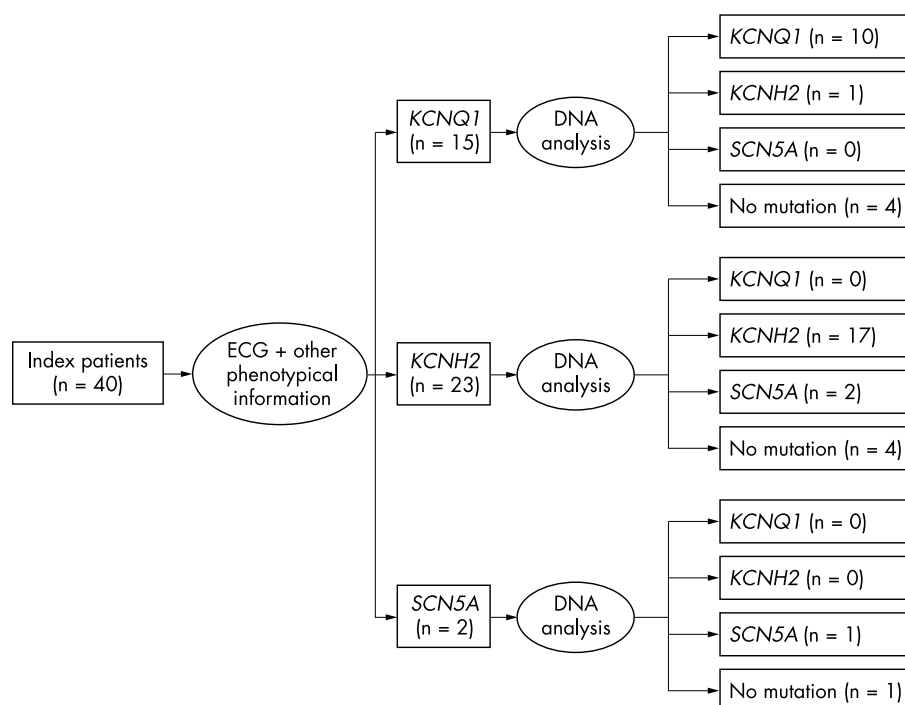

Figure 1 Predicted genotypes of 40 index patients after provision of ECG and other phenotypic information, as compared to genotypes established by DNA analysis.

DISCUSSION

We investigated whether phenotype directed genotyping in LQTS might increase efficiency compared to screening based on prevalences only. The proportion of correct predictions of the mutated gene is significantly increased to 90% of cases with established genotypes when phenotypic information is added. Hence, reliable identification of risk carrying relatives can be achieved relatively quickly and at low cost in 70% of all LQTS affected families. The favourable inter-observer agreement supports the reliability of this prediction method.

As in the reference group, *KCNH2* was the most frequently mutated gene in our study but the prevalence of *KCNH2* mutations was considerably higher here (45% *v* 58%). As a result, predictions solely based on prevalence data from the reference population would have led to higher yields in our population than expected, slightly reducing the added value of phenotypic information in this specific patient group. Still, even in this group, predictions based on phenotypic data (90%) were much better than predictions based on prevalence data in the reference group (18 of 31 patients, 58%, with *KCNH2* mutations in our study group). In different populations, with unknown background prevalences, the use of individual phenotypic data to assign the most eligible mutated gene becomes even more important.

Zhang *et al*¹⁷ described an alternative method to predict the affected gene in LQTS on the basis of 10 characteristics of the ECGs of patients and their relatives.¹⁷ The gene was predicted successfully in 80% (63/81) of genotyped families. However, a clear candidate gene could be assigned only in 63% (80/127) of all families. Contrary to our findings, Zhang *et al*¹⁷ concluded that the availability of ECGs (from multiple relatives) improved prediction rates. Our prediction method reaches (at least) the same prediction rates but is more robust.

Limitations

Despite meeting accepted LQTS criteria, mutations were only found in 78% (31/40) of cases. This may be because of false negative results probably being caused by the relatively low sensitivity of SSCP analysis for mutation screening, compared to that of more advanced techniques like DHPLC. Alternatively, more LQTS genes may exist than the five genes that were tested in our study and deletions and mutations outside the screened coding regions of the known genes may have been missed.

Two mutations in different genes were identified in one patient (1/40). This is in accordance with the reported rate of double mutations in *KCNQ1*, *KCNH2*, and *SCN5A* (approximately 3% of cases).^{17,21} We did not study whether other patients had mutations in more than one gene other than *KCNE1* and *KCNE2*. It is not expected that the finding of more than one mutation has clinical implications for medical treatment in the index patient. Nevertheless, these findings may be relevant for relatives, probably being at risk for acquired LQTS (in which symptoms are only to be expected in triggering circumstances, like the use of certain medications) when carrying only one of the mutations. Prognostic research should first clarify the clinical consequences, if any, before diagnostic screening is extended to corroborate the existence of more than one mutation in all patients.

Both cardiologists in our study are experts in the field of LQTS. Their good inter-observer agreement most probably reflects their long experience in judging ECG morphology in this disease. We did not test the predictive ability of less experienced cardiologists, but we assume that these would be somewhat less.

Proposed strategy for diagnostic services in LQTS

While considering the genetic heterogeneity in LQTS and the limitations of current techniques used in DNA diagnosis, we still recommend DNA diagnosis in all known LQTS families.

Cost effective and fast screening of index patients is possible by limiting diagnosis to the one most eligible gene based on phenotypic information. This requires that knowledgeable cardiologists are involved in the intake procedure of diagnostic laboratories and that referring cardiologists provide ECGs and clinical data together with the blood samples of their LQTS patients. The prediction of the most eligible gene should be based on age of onset of symptoms, triggers, ECG morphology (index and/or relatives), and relevant published background prevalences. If a mutation is detected, DNA based screening of (asymptomatic) relatives can be offered. In our experience, an additional five to ten DNA tests for a certain mutation will be requested during this cascade screening.

If no causative mutation can be identified, only cardiologic screening of relatives can be offered. Owing to potentially reduced penetrance, formal cascade screening is not possible here.²² Further DNA screening for research purposes in the index patient could be discussed with cardiologists and molecular geneticists involved in research in this field. The same applies for screening of other genes with the purpose of finding second mutations after one mutation has already been found.

The strategy proposed here will have to be adjusted when future diagnostic techniques (for example, DNA chips) make simultaneous screening of several genes possible at a lower cost. However, we do not expect these developments to be of practical use in the next few years.

ACKNOWLEDGEMENTS

We are indebted to all families who participated in this study. We also thank all the referring cardiologists, especially Professor R Tavernier (University Hospital, Gent). We are also grateful to C R Bezzina and H L Tan, for critical reading and revision of the manuscript. This study was supported in part by The Netherlands Heart Foundation (grant No NHS 95.014) and The Netherlands Interuniversity Cardiologic Institute (ICIN, project 27).

.....

Authors' affiliations

I M Van Langen, M Alders, Department of Clinical Genetics, Academic Medical Centre, Meibergdreef 9, 1105 AZ Amsterdam, The Netherlands

E Birnie, Department of Social Medicine, Academic Medical Centre, Meibergdreef 9, 1105 AZ Amsterdam, The Netherlands

R J Jongbloed, Division of Genetics and Cell Biology, University of Maastricht, Joseph Bechlaan 113, 6229 GR, Maastricht, The Netherlands

H Le Marec, Clinique Cardiologique, Hôpital G&R Laënnec, CHU de Nantes, 44093 Nantes Cedex, France

A A M Wilde, Experimental and Molecular Cardiology Group, Academic Medical Centre, Meibergdreef 9, 1105 AZ Amsterdam, and The Netherlands Interuniversity Cardiologic Institute (ICIN), Catharijnesingel 52, 3501 DG Utrecht, The Netherlands

Correspondence to: Dr I M van Langen, Department of Clinical Genetics, Academic Medical Centre, Meibergdreef 9, 1105 AZ Amsterdam, The Netherlands; i.m.vanlangen@amc.uva.nl

REFERENCES

- 1 **Piippo K**, Swan H, Pasternack M, Chapman H, Paavonen K, Viitasalo M, Toivonen L, Kontula K. A founder mutation of the potassium channel *KCNQ1* in long QT syndrome. Implications for estimation of disease prevalence and molecular diagnostics. *J Am Coll Cardiol* 2001;**37**:562-8.
- 2 **Schwartz PJ**, Moss AJ, Vincent GM, Crampton RS. Diagnostic criteria for the long QT syndrome: an update. *Circulation* 1993;**88**:782-4.
- 3 **Zareba W**, Moss AJ, leCessie S, Locati EH, Robinson JL, Jackson Hall W, Andrews ML. Risk of cardiac events in family members of patients with long QT syndrome. *J Am Coll Cardiol* 1995;**26**:1685-91.
- 4 **Vincent GM**, Zhang L, Timothy KW, Fox J. Long QT syndrome patients with normal to borderline prolonged QTc intervals are at risk for syncope, cardiac arrest and sudden death. *Circulation* 1999;**100**:1272-2.
- 5 **Kaufman ES**, Priori SG, Napolitano C, Schwartz PJ, Iyengar S, Elston RC, Schnell AH, Gorodeski EZ, Rammohan G, Bahur NO, Connuck D, Verrilli L, Rosenbaum DS, Brown AM. Electrocardiographic prediction of abnormal genotype in congenital long QT syndrome: experience in 101 related family members. *J Cardiovasc Electrophysiol* 2001;**12**:455-61.

- 6 **Moss AJ**, Zareba W, Hall WJ, Schwartz PJ, Crampton RS, Benhorin J, Vincent GM, Locati E, Priori SG, Napolitano C, Medina A, Zhang L, Robinson J, Timothy K, Towbin JA, Andrews ML. Effectiveness and limitations of beta-blocker therapy in congenital long QT syndrome. *Circulation* 2000;**101**:616-23.
- 7 **Splawski I**, Shen J, Timothy KW, Lehmann MH, Priori S, Robinson JL, Moss AJ, Schwartz PJ, Towbin JA, Vincent GM, Keating MT. Spectrum of mutations in long-QT syndrome genes KVLQT1, HERG, SCN5A, KCNE1 and KCNE2. *Circulation* 2000;**102**:1178-85.
- 8 **Vincent MG**, Timothy K, Zhang L. Congenital Long QT Syndrome. *Cardiac Electrophysiol Rev* 2002;**6**:57-60.
- 9 **Vincent MG**. Role of DNA testing for diagnosis, management and genetic screening in long QT syndrome, hypertrophic cardiomyopathy, and Marfan syndrome. *Heart* 2001;**86**:12-14.
- 10 **Priori SG**, Barhanin J, Hauer R, Haverkamp W, Jongsma HJ, Kleber AG, McKenna WJ, Roden DM, Rudy Y, Schwartz K, Schwartz PJ, Towbin JA, Wilde AM. Genetic and molecular basis of cardiac arrhythmias: impact on clinical management. Parts I and II. *Circulation* 1999;**99**:518-28.
- 11 www.eddnl.com, www.genetests.com, accessed 13-02-2002.
- 12 **Wilde AAM**, Roden DM. Predicting the long QT genotype from clinical data. *Circulation* 2000;**102**:2796-8.
- 13 **Schwartz PJ**, Priori SG, Spazzolini C, Moss AJ, Vincent GM, Napolitano C, Denjoy I, Guicheney P, Breithardt G, Keating MT, Towbin JA, Beggs AH, Brink P, Wilde AAM, Toivonen L, Zareba W, Robinson J, Timothy KW, Corfield V, Watanasirichaigoon D, Corbett C, Haverkamp W, Schulze-Bar E, Lehmann MH, Schwartz K, Coumel P, Bloise R. Genotype-phenotype correlation in the long-QT syndrome. Gene-specific triggers for life-threatening arrhythmias. *Circulation* 2001;**103**:89-95.
- 14 **Ackerman MJ**, Teser DJ, Porter CJ. Swimming, a gene-specific arrhythmogenic trigger for inherited long-QT syndrome. *Mayo Clin Proc* 1999;**74**:1088-94.
- 15 **Wilde AAM**, Jongbloed RJ, Doevendans PA, Düren DR, Hauer RN, van Langen IM, van Tintelen JP, Smeets HJ, Meyer H, Geelen JL. Auditory stimuli as a trigger for arrhythmic events differentiate HERG-related (LQTS2) patients from KVLQT1-related patients (LQTS1). *J Am Coll Cardiol* 1999;**33**:327-32.
- 16 **Moss AJ**, Zareba W, Benhorin J, Locati EH, Hall WJ, Robinson JL, Schwartz PJ, Towbin JA, Vincent GM, Lehmann MH. ECG T-wave patterns in genetically distinct forms of the hereditary long QT syndrome. *Circulation* 1995;**92**:2929-34.
- 17 **Zhang L**, Timothy KW, Vincent GM, Lehmann MH, Fox J, Giuli LC, Shen J, Splawski I, Priori S, Compton SJ, Yanowitz F, Benhorin J, Moss AJ, Schwartz PJ, Robinson J, Wang Q, Zareba W, Keating M, Towbin JA, Napolitano C, Medina A. The spectrum of ST-T wave patterns and repolarization parameters in congenital long QT syndrome: ECG findings identify genotype. *Circulation* 2000;**102**:2849-55.
- 18 **Lupoglazoff JM**, Denjoy I, Berhet M, Neyroud N, Demay L, Richard P, Hainque B, Vaksman G, Klug D, Leenhardt A, Maillard G, Coumel P, Guicheney P. Notched T waves on Holter recordings enhance detection of patients with LQT2 (HERG) mutations. *Circulation* 2001;**103**:1095-101.
- 19 **Moss AJ**, Robinson JL, Gessman L, Gillespie R, Zareba W, Schwartz PJ, Vincent GM, Benhorin J, Locati Heilbron E, Towbin JA, Priori SG, Napolitano C, Zhang L, Medina A, Andrews ML, Timothy K. Comparison of clinical and genetic variables of cardiac events associated with loud noise versus swimming among subjects with the long QT syndrome. *Am J Cardiol* 1999;**84**:876-9.
- 20 **Cotton RGH**, Scriver CR. Proof of 'disease causing' mutation. *Hum Mutat* 1998;**12**:1-3.
- 21 **Napolitano C**, Memmi M, Shimizu W, Ronchetti E, Correia MJ, Schwartz PJ, Priori SG. Double mutations in LQTS and Brugada syndrome patients: analysis of 130 genotyped probands. *Circulation* 2000;**102**(suppl):II-358A.
- 22 **Priori SG**, Napolitano C, Schwartz PJ. Low penetrance in the long-QT syndrome. Clinical impact. *Circulation* 1999;**99**:529-33.

What's in the next issue

Future content

See which articles have just been accepted for publication and preview the table of contents for the next issue a month before it is published

www.jmedgenet.com